

**Performance**

Lifting height	10290.0 mm
Rated capacity	3500 kg
Capacity (at max. height)	400 kg
Capacity (at max. reach)	600 kg
Max. reach	6886.0 mm
Crowding force	7800 daN

**Weights**

Weight (unladen)	7420 kg
------------------	---------

**Traction**

Standard tyres	SOLIDEAL 405/70-20 14PR
1st gear / low range	8.5 km/h
2nd gear / high range	30.0 km/h

**Drive System**

Main drive	Hydrostatic motor
Transmission	Hydrostatic with electronic regulation

**Engine**

Make / Model	Deutz TCD 3.6 L4
Fuel	Diesel
Cooling	Liquid
Rated power (ISO 14396:2002) at 2300 RPM	74.4 kW
Maximum torque at 1600 RPM:	410.0 Nm
Number of cylinders	4
Displacement	3.62 L

**Hydraulic System**

Pump type	Gear pump with LS valve
-----------	-------------------------

**Cycle Times**

Lift time - no load	9.8 s
Lower time - no load	6.0 s
Telescope in time at max. reach - no load	7.0 s
Telescope in time at max. height - no load	7.0 s
Telescope out time at max. reach - no load	10.4 s
Telescope out time at max. height - no load	10.4 s

**Brakes**

Engine braking	Hydrostatic
Parking and emergency brake	Negative brake with hydraulic command

**Fluid Capacities**

Fuel tank	130.00 L
Hydraulic reservoir	71.00 L

**Environmental**

Operator noise level (LpA) (EN 12053)	76 dB(A)
Level of acoustic power (LWA)	106 dB(A)
Whole body vibration (EN 13059)	0.90 ms <sup>-2</sup>

**Load Charts**

With forks and standard 405/70x20 tyres

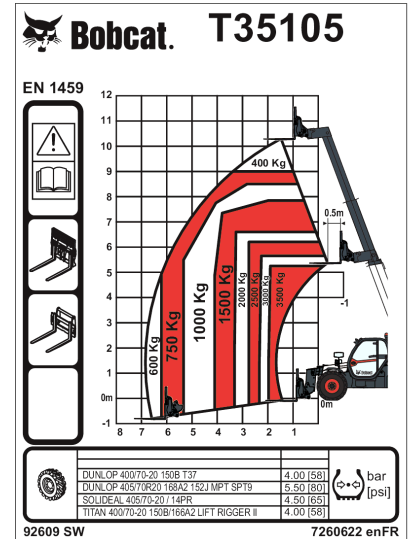
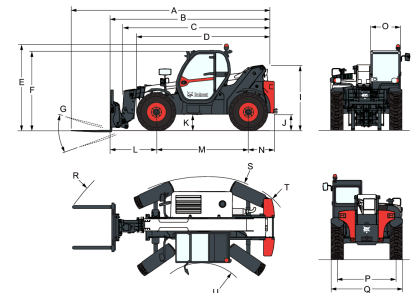
**Dimensions**

(-)	857.0 mm	(L)	1422.0 mm
(A)	6276.0 mm	(M)	2850.0 mm
(B)	5071.0 mm	(N)	799.0 mm
(C)	4936.0 mm	(O)	930.0 mm
(D)	4192.0 mm	(P)	1862.0 mm
(E)	2584.0 mm	(Q)	2264.0 mm
(F)	2389.0 mm	(R)	5025.0 mm
(G)	143.0°	(S)	5116.0 mm
(I)	1941.0 mm	(T)	3765.0 mm
(J)	415.0 mm	(U)	1245.0 mm