

**Performance**

Lifting height — on tyres	6889.0 mm
Rated capacity	3800 kg
Capacity (at max. height on tyres)	3500 kg
Capacity (at max. reach on tyres)	1500 kg
Max. reach on tyres	4002.0 mm

**Weights**

Weight (unladen)	7440 kg
------------------	---------

**Traction**

Standard tyres	SOLIDEAL 405/70-20 14PR
1st gear / low range (40 km/h option)	6 (6) km/h
1st gear / high range (40 km/h option)	11 (12) km/h
2nd gear / low range (40 km/h option)	16 (18) km/h
2nd gear / high range (40 km/h option)	30 (40) km/h

**Drive System**

Main drive	Hydrostatic motor + 2 speed gearbox
Transmission	Hydrostatic with electronic regulation

**Engine**

Make / Model	Bobcat D34
Fuel	Diesel
Cooling	Coolant
Rated power (ISO 14396:2002) at 2400 RPM	97.0 kW
Maximum torque at 1400 RPM	500.0 Nm
Number of cylinders	4
Displacement	3.40 L

**Hydraulic System**

Pump type	LS piston pump with electric displacement limiter
-----------	---

**Cycle Times**

Lift time - no load	4.9 s
Lower time - no load	4.3 s
Telescope in time at max. reach - no load	4.8 s
Telescope in time at max. height - no load	4.8 s
Telescope out time at max. reach - no load	4.9 s
Telescope out time at max. height - no load	4.7 s

**Brakes**

Engine braking	Hydrostatic
Parking and emergency brake	Passive brake

**Fluid Capacities**

Fuel tank	138.00 L
Hydraulic reservoir	59.00 L

**Environmental**

Operator noise level (LpA) (EN 12053)	77 dB(A)
Level of acoustic power (LWA)	107 dB(A)
Whole body vibration (EN 13059)	1.20 ms <sup>-2</sup>

**Load Charts**

With forks on 20 inch tyres

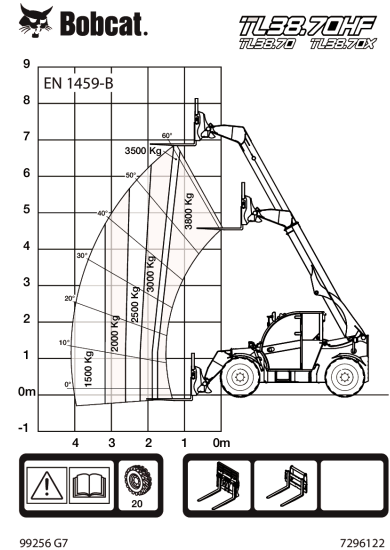
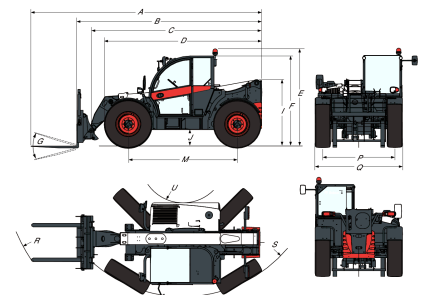
**Dimensions**

(-) 900.0 mm	(L) 1356.0 mm
(A) 6074.0 mm	(M) 2870.0 mm
(B) 4869.0 mm	(N) 643.0 mm
(C) 4763.0 mm	(O) 1013.0 mm
(D) 4058.0 mm	(P) 1895.0 mm
(E) 2477.0 mm	(Q) 2300.0 mm
(F) 2290.0 mm	(R) 4925.0 mm
(G) 135.0°	(S) 5015.0 mm
(I) 1668.0 mm	(T) 3714.0 mm
(J) 346.0 mm	(U) 1092.0 mm