

**Weights**

Operating weight	5930 kg
Additional weight for long dipperstick	23 kg

**Engine**

Make / model	Bobcat / D24
Fuel	Diesel
Number of cylinders	4
Displacement	2392 cm <sup>3</sup>
Maximum NET power (ISO 14396)	42.5 kW
Maximum NET torque (ISO 14396)	204.0 Nm

**Performance**

Digging force, dipperstick (ISO 6015)	27459 N
Digging force, long dipperstick (ISO 6015)	24517 N
Digging force, bucket (ISO 6015)	41188 N
Drawbar pull	32362 N
Travel speed, low range	10.0 km/h
Travel speed, high range	30.0 km/h

**Hydraulic System**

Pump type	Split engine-driven axial piston pump and two engine-driven gear pumps
Pump capacity	180.30 L/min
Auxiliary flow	52.50 L/min
System relief pressure for auxiliary circuit 3	226.00 bar
System relief pressure for auxiliary circuit 2	235.00 bar

**Slew System**

Boom swing, left	80.0°
Boom swing, right	50.0°
Slew rate	9.4 RPM

**Fluid Capacities**

Cooling system	11.20 L
Engine lubrication plus oil filter	9.20 L
Fuel reservoir	118.00 L
Hydraulic system	148.00 L

**Environmental**

Noise level LpA(EU Directive 2006/42/EC)	75 dB(A)
Noise level LWA(EU Directive 2000/14/EC)	98 dB(A)
Whole body vibration (ISO 2631-1)	0.56 ms <sup>-2</sup>
Hand-arm vibration (ISO 5349-1)	0.54 ms <sup>-2</sup>

**Standard Features**

Boom load holding valve	Horn
Dozer blade safety valve	Work lights
Fully adjustable air conditioning	Retractable seat belt
Heated suspension seat with high back	TOPS/ROPS cab <sup>1</sup>
Consoles with forwards/backwards adjustable displacement	Harness for rotating beacon
Steering column with adjustable angle	Overload warning device
Second auxiliary hydraulic line (Rotation piping)	Sun visor
Fingertip auxiliary hydraulic control	Two left and one right rear view mirrors
Control console locks	Electric refueling pump
Hydraulic joystick controls	Auto idle
Two-speed travel	Warranty: 12 months, 2000 hours (whichever occurs first)
Lockable storage compartment	7 inch Deluxe screen

1. Tip Over Protective Structure (TOPS) – Meets requirements of ISO 12117

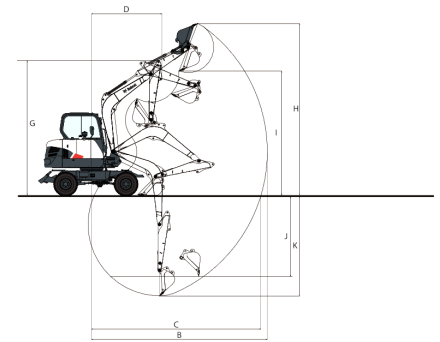
**Working Range**

(A)	180.0°	(G)	4686.0 mm
(B)	6108.0 mm	(H)	5976.0 mm
(B)	6400.0 mm	(H)	6170.0 mm
(C)	5888.0 mm	(I)	4324.0 mm
(C)	6190.0 mm	(I)	4510.0 mm
(D)	2448.0 mm	(J)	2805.0 mm
(D)	2464.0 mm	(J)	3115.0 mm
(E)	421.0 mm	(K)	3495.0 mm
(F)	202.0 mm	(K)	3795.0 mm

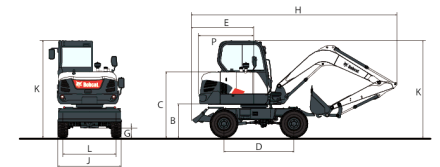
**Dimensions**

(A)	500.0 mm	(J)	1920.0 mm
(B)	980.0 mm	(J)	2290.0 mm
(C)	1935.0 mm	(K)	2950.0 mm
(D)	2100.0 mm	(L)	1600.0 mm
(E)	1678.0 mm	(O)	1980.0 mm
(F)	4260.0 mm	(P)	1650.0 mm
(H)	6120.0 mm		

**Options**

Long dipperstick	Third auxiliary hydraulic line (Clamshell Piping)
Twin tyres with 2290 mm dozer blade	