

# TL26-60 100 High Cab V R-Series

## Telescopic Specifications

### Performance

Rated capacity	2600 kg
Capacity (at max. height on tyres)	2000 kg
Capacity at max. reach	950 kg
Lifting height	5800.0 mm
Tilt Breakout force	4600 daN
Drawbar pull (20" tyres)	4900 daN
Drawbar pull (24" tyres)	4100 daN
Max. gradeability (20" tyres)	33.0°
Max. gradeability (24" tyres)	33.0°
Max. reach	3100.0 mm

### Cycle times

Boom raising	5.3 s
Boom lowering	4.0 s
Boom extension	5.0 s
Boom retraction	3.6 s
Crowding	2.5 s
Dumping	2.4 s

### Weights

Unladen weight (20" tyres)	4840 kg
Unladen weight (24" tyres)	4960 kg

### Engine

Make / Model	Bobcat D34
Fuel	DIESEL
Rated power (ISO 14396)	74.5 kW
Rated speed	2400.0 RPM
Maximum torque at 1400 rpm	430.0 Nm
Number of cylinders	4.0
Displacement	3.40 L

### Hydraulic system

Pump type	Gear pump with LS valve
Pump capacity	100.00 L/min
Relief valve pressure setting	250.00 bar
Control valve type	Open center with flow sharing & flow compensators technology

### Drive system

Transmission	Hydrostatic with electronic regulation
Main Drive	Hydrostatic motor

### Traction

Standard Tyres	CAMSO 405/70-20 16PR TM R4
Max speed - turtle mode (24" / 20")	10 / 8.5
Max speed - rabbit mode (24" / 20")	31 / 26.5
Max speed - turtle mode (24" / 20") - (Option high speed)	10 / 8.5
Max speed - rabbit mode (24" / 20") - (Option high speed)	40 / 35

### Brakes

Engine Braking	Hydrostatic
Parking and Emergency brake	Passive brake
Service Brake	Oil immersed discs

### Steering

Steering Mode	wheel steering / 4 wheel steering / Crab-steering
---------------	---

### Fluid Capacities

Fuel tank	115.00 L
Adblue ® tank	22.40 L
Hydraulic tank	47.00 L
Hydraulic system	87.00 L

### Environmental

Operator noise level (LpA) (EN 12053)	76 dB(A)
Level of acoustic power (LwA)	106 dB(A)
Whole body vibration (EN 13059)	1.80 ms <sup>-2</sup>

### Dimensions

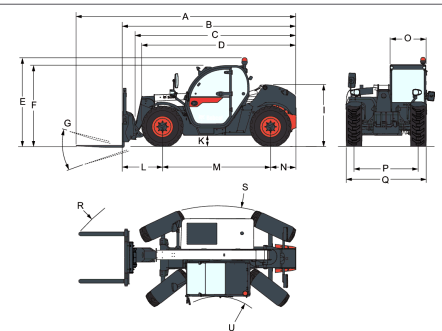

Values marked with \* - HighCab 24" tyres

(A)	5712.0 mm	(K*)	348.0 mm
(B)	4507.0 mm	(L)	1020.0 mm
(C)	4140.0 mm	(M)	2820.0 mm
(D)	4035.0 mm	(N)	667.0 mm
(D*)	4123.0 mm	(O)	930.0 mm
(E)	2440.0 mm	(P)	1666.0 mm
(E*)	2524.0 mm	(Q)	2100.0 mm
(F)	2290.0 mm	(R)	4713.0 mm
(F*)	2375.0 mm	(R*)	4820.0 mm
(G)	136.0°	(S)	3717.0 mm
(I)	1587.0 mm	(S*)	3875.0 mm
(I*)	1671.0 mm	(U)	1329.0 mm
(K)	264.0 mm	(U*)	1503.0 mm

### Load Charts

Load Charts

