

Weights

Operating weight with canopy and bucket (ISO 6016)	1907 kg
Transport mass (no attachment)	1794 kg
Additional weight for long dipperstick	6 kg
Ground pressure with rubber tracks	32.90 kPa

Engine

Make / model	Schabmueller / Electric AM (TSA200)
Voltage	32AC
Maximum power @ 2700 RPM	10.0 kW
Maximum torque @ 2700 RPM	35.0 Nm

Powertrain Battery

Model	Li-Ion
Voltage	51.8 VDC
Capacity	17,28 kWh (3x 5.76)

Hydraulic System

Pump type	Triple gear pump
Total hydraulic capacity	35.00 L/min
Auxiliary (AUX1) flow	24.30 L/min
Auxiliary (AUX2) flow	15.00 L/min
Auxiliary (AUX1) relief	180.00 bar
Auxiliary (AUX2) relief	179.00 bar

Performance

Digging force, dipperstick (ISO 6015)	10371 N
Digging force, long dipperstick (ISO 6015)	9279 N
Digging force, bucket (ISO 6015)	20835 N
Drawbar pull	23550 N
Travel speed, low range	1.7 km/h
Travel speed, high range	3.7 km/h

Slew System

Boom swing, left	80.0°
Boom swing, right	60.0°
Slew rate	7.9 RPM

Fluid Capacities

Hydraulic reservoir	14.30 L
Hydraulic system	19.00 L

Environmental

Noise level LpA(EU Directive 2006/42/EC)	75 dB(A)
Noise level LWA(EU Directive 2000/14/EC)	86 dB(A)
Whole body vibration (ISO 2631-1)	0.58 ms ⁻²
Hand-arm vibration (ISO 5349-1)	1.81 ms ⁻²

Standard Features

230 mm rubber track	LED Work lights
980 mm dozer blade with two 190 mm blade extensions	Lithium-ion batteries
Adjustable double acting auxiliary hydraulic (AUX1) with Quick Couplers	Long dozer blade
Batteries disconnect switch	Machine IQ (telematic)
Control console locks	On-board charger 110/230 V
Cupholders	Proportional fingertip auxiliary and boom swing offset hydraulic control
Dual Direction Detent	Retractable seat belt
Electric A/C motor	Seat with high back
Engine/hydraulic monitor with shutdown	Storage compartment
Exposed counterweight with 4 mm steel tailgate	Two-speed travel with Auto shift
Foldable and ergonomic pedals	TOPS/ROPS/FOPS canopy *1 1
Horn	HD travel motors
Hydraulic and travel control lockout	Upper structure four-point tie down
Hydraulic joystick controls	Warranty: 24 months, 2000 hours (whichever occurs first)
Hydraulically retractable undercarriage from 1360 mm to 980 mm	

1. 1. Roll Over Protective Structure (ROPS) – Meets requirements of ISO 3471. Tip Over Protective Structure (TOPS) – Meets requirements of ISO 12117. Falling Object Protective Structure (FOPS) - Meets requirements of ISO 3449.

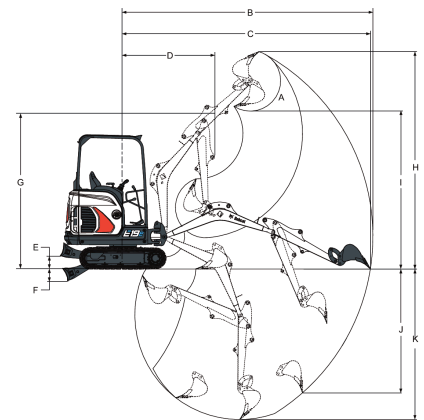
Working Range

Values marked with * - Long dipperstick

(A)	196.0°	(G)	2564.0 mm
(B)	4084.0 mm	(H)	3573.0 mm
(B*)	4257.0 mm	(H*)	3701.0 mm
(C)	4039.0 mm	(I)	2566.0 mm
(C*)	4214.0 mm	(I*)	2693.0 mm
(D)	1542.0 mm	(J)	1948.0 mm
(D*)	1561.0 mm	(J*)	2115.0 mm
(E)	220.0 mm	(K)	2385.0 mm
(F)	204.0 mm	(K*)	2565.0 mm

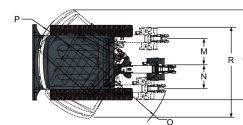
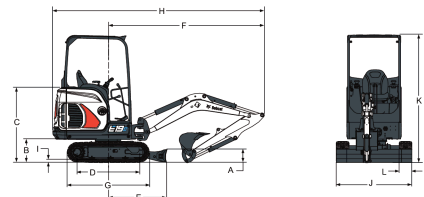
Dimensions

(A)	235.0 mm	(J)	980.0 mm
(B)	419.0 mm	(J*)	1360.0 mm
(C)	1340.0 mm	(K)	2299.0 mm
(D)	1114.0 mm	(L)	230.0 mm
(E)	1045.0 mm	(M)	433.0 mm
(F)	2832.0 mm	(N)	589.0 mm
(G)	1476.0 mm	(O)	1154.0 mm
(H)	3831.0 mm	(P)	1009.0 mm
(H*)	3812.0 mm	(Q)	1801.0 mm
(I)	25.0 mm	(R)	1645.0 mm

Options

Demolition package (boom, arm, bucket cylinder covers & HD travel hoses guard)	Special application kit
Object handling package (Valves, OWD, Liftye)	Supercharger unit 400V
Long dipperstick w/ clamp eyes	L/R mirrors
AUX1 direct return to tank	Rear LED light Kit
AUX2 hydraulics	Fire extinguisher
AUX1/AUX2 on arm	Hydraulic clamp
Travel motion alarm	Klacc C and MS01 couplers
Beacon	Grease Gun w/ holder