

Weights

Operating weight with standard bucket, excluding operator	8380 kg
Additional weight for long dipperstick	58 kg
Ground pressure with rubber tracks	38.25 kPa

Engine

Make / model	Yanmar / 4TNV98-ZWDB8
Fuel	Diesel
Number of cylinders	4
Displacement	3300 cm ³
Maximum NET power (ISO 9249)	40.4 kW
Maximum torque at 1300 RPM	248.0 Nm

Hydraulic System

Pump type	One engine-driven tandem axial piston pump and one engine-driven gear pump
Piston pump capacity	144.00 L/min
Auxiliary flow	120.00 L/min
Auxiliary relief	210.0 bar

Performance

Digging force, dipperstick (ISO 6015)	40900 N
Digging force, long dipperstick (ISO 6015)	34100 N
Digging force, bucket (ISO 6015)	54600 N
Drawbar pull	60800 N
Travel speed, low range	2.9 km/h
Travel speed, high range	4.6 km/h

Slew System

Boom swing, left	70.0°
Boom swing, right	55.0°
Slew rate	9.6 RPM

Fluid Capacities

Cooling system	4.20 L
Engine lubrication plus oil filter	11.60 L
Fuel reservoir	110.00 L
Hydraulic reservoir	87.00 L
Hydraulic system	127.00 L

Environmental

Noise level LpA(EU Directive 2006/42/EC)	77 dB(A)
Noise level LWA(EU Directive 2000/14/EC)	98 dB(A)

Standard Features

2300 mm dozer blade	Boom and arm load holding valve
450 mm rubber tracks	Harness for rotating beacon
Engine/hydraulic monitor with shutdown	Fully adjustable air conditioning
Fingertip auxiliary hydraulic control	Overload warning device
Control console locks	Sun visor
Hydraulic joystick controls	Left rear view mirror
Two-speed travel	Electric refueling pump
Lockable storage compartment	Auto idle
Horn	Second auxiliary hydraulic line (Rotation piping)
Work lights	Auxiliary hydraulics (1st and 2nd circuits)
Retractable seat belt	Auxiliary lines on arm with quick couplers
Suspension seat with high back	Warranty: 24 months, 2000 hours (whichever occurs first)
Consoles with forwards/backwards adjustable displacement	

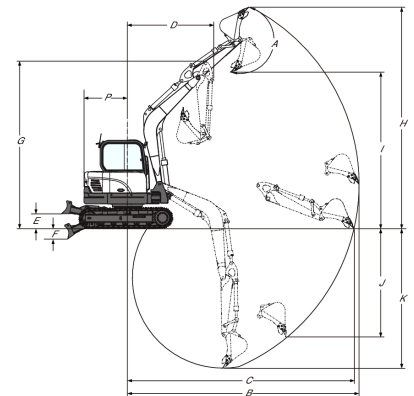
Working Range

(A)	182.0°	(G)	5019.0 mm
(B)	6965.0 mm	(H)	6715.0 mm
(B)	7480.0 mm	(H*)	7070.0 mm
(C)	6765.0 mm	(I)	4720.0 mm
(C*)	7295.0 mm	(I*)	5085.0 mm
(D)	2500.0 mm	(J)	3220.0 mm
(D*)	2700.0 mm	(J)	3730.0 mm
(E)	438.0 mm	(K)	4150.0 mm
(F)	310.0 mm	(K*)	4675.0 mm

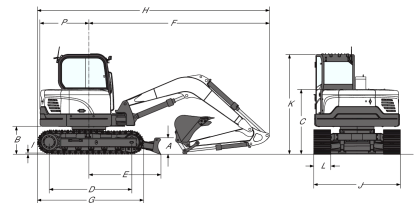
Dimensions

(A)	440.0 mm	(I)	20.0 mm
(B)	737.0 mm	(J)	2300.0 mm
(C)	1715.0 mm	(K)	2638.0 mm
(D)	2200.0 mm	(L)	450.0 mm
(E)	1912.0 mm	(M)	655.0 mm
(F)	4797.0 mm	(N)	803.0 mm
(G)	2823.0 mm	(O)	2500.0 mm
(H)	6167.0 mm	(P)	1298.0 mm
(H*)	6260.0 mm	(Q)	2450.0 mm

Options

Steel tracks	Long dipperstick
Third auxiliary hydraulic line (Clamshell Piping)	